



QASHQAI





Taking QASHQAI to the next level

With the launch of the first generation Nissan QASHQAI in 2006, Nissan pioneered the now incredibly popular C-SUV segment globally. Nissan Australia introduced the first generation QASHQAI, badged Dualis, in 2007 and the vehicle quickly became a best-seller in the Nissan range.

The latest generation of the Nissan QASHQAI brings a bolder design, interior comfort and enhanced connectivity and safety equipment, aimed at elevating your everyday drive.

**DRIVEN BY ELECTRIC. FUELLED BY PETROL.
NEVER NEED TO PLUG IN.**

The QASHQAI Ti is also available with e-POWER* - a technology that goes beyond traditional hybrid powertrains. It offers a smooth, responsive and quiet EV-like driving experience without the need plug-in to recharge.

*e-POWER is available on Ti only.

Images and descriptions shown are for guidance purposes. In some instances photos are of non-local specification vehicles and do not represent a specific model or grade. The features shown may not be available or may not be available as standard or only as option. QASHQAI Ti with optional two-tone roof shown throughout.

Brochure updated April 2024.

A Bold Form of Expression

QASHQAI brings a bold vision to crossover design with muscular proportions, a vibrant palette including a variety of two-tone colour options*, brilliant LED lighting, low-profile aluminium roof rails† and imposing 19" alloy wheels‡.



A
LED
Headlamps

B
LED Rear
lamps

C
Stamped
QASHQAI
branding

D
Two-tone
roof[†]

E
19" Alloy
Wheels[‡]

*Not available on ST.
†Available only on ST-L & Ti.
‡Available at an additional cost.





Enjoy an exciting and unplugged EV-like driving experience with New QASHQAI e-POWER*

With e-POWER*, pioneering doesn't have to pause. e-POWER* is an innovative powertrain system which includes two electric motors, a petrol engine and a lithium-ion battery to achieve an EV-like driving experience. The result is almost instant acceleration response and a quiet driving sensation without the need to plug in or recharge. Just exhilarating and stress-free driving with no compromise on fuel economy.

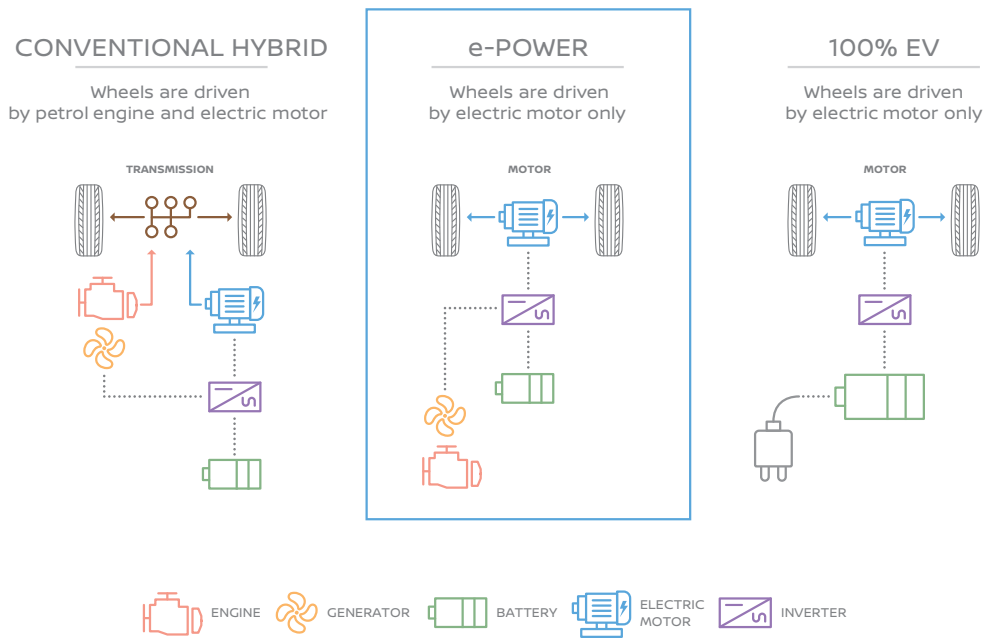

SIMPLIFIED ELECTRIC DRIVE WITH e-PEDAL STEP*
 Experience a more intuitive way to drive. The e-Pedal Step[^] gives you the option to accelerate and decelerate effectively with just the accelerator pedal at speeds above 10km/h, leaving the brake pedal for harder braking or coming to a complete stop.

* e-POWER is available on Ti only.
[^] The e-Pedal Step is a driver's aid only and should not be used as a substitute for safe driving practices. Always monitor your surroundings when driving. It may not be suitable under all driving conditions, correct operation is the responsibility of the driver. Available on e-POWER only.

Refined design and seductive functionality

Everything about the interior of the Nissan QASHQAI feels advanced and premium. From its steering wheel to its centre console, everything has been ergonomically designed for total driving comfort. Enhanced screen visibility and seamless tech integration helps you stay alert and focused on any drive.

Appreciate the clarity of the 10.8" Head-up display*, 12.3" TFT Advanced Drive-Assist® Display instrument cluster* and 12.3" infotainment display^.

The three large screens work together in perfect harmony for a safer, clearer, more optimised driving experience.



Ti interior shown.



12.3" TFT Advanced Drive-Assist® Display instrument cluster*



Fast (15W) wireless charger#



e-POWER shifter~

*Available on Ti only.

^Available on ST+ and above.

#Available on ST-L and Ti only. Compatible device required.

~ Available on e-POWER models only.

CarPlay is a registered trademark of Apple Inc. Compatible device required. Wired connections require a USB connection. Wireless CarPlay® available on ST+ and above.



Ti interior shown.

Room for everyone. And more

Nissan QASHQAI combines a spacious interior and generous boot space with a compact, city-friendly exterior for easy manoeuvrability. Passengers sit in comfort thanks to the QASHQAI's roomy interior and easy rear seat access - both for passengers and child seat fitment, with an 85° rear door opening. Thoughtful small touches like two USB charging ports and rear air vents for passengers are also available, ensuring every seat is the best in the house.



Ti interior shown.

Your personal space has never felt more personal

Relax in ergonomically designed seats and feel the comfort on even the longest journeys with optimised lumbar support. Been a long day? With premium-quilted leather-accented seats in the Ti**, activate QASHQAI's massage seats*, for both driver and passenger, and feel the stress disappear. With quality finishes throughout and enhanced safety, thanks to a central airbag, not only will your everyday drive feel elevated, but you'll also have the peace-of-mind for all the family.

CENTRAL AIRBAG

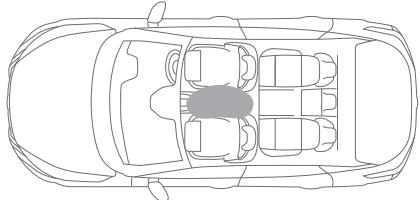

*Massage Seats are only available on Ti grade.
**Leather accented features and upholstery may contain synthetic material.



Handsfree power tailgate*

UP TO 452L BOOT SPACE

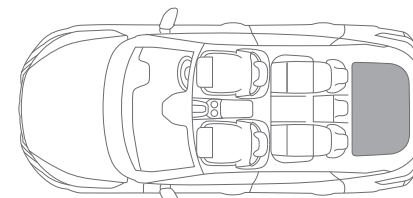

ST / ST+ / ST-L	429L
Ti	418L
Ti e-POWER	452L

UP TO 1,524L WITH FOLDED SEATS

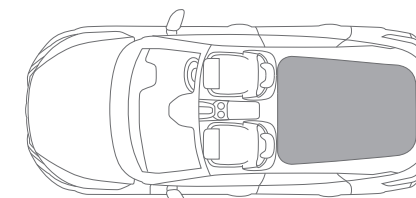

ST / ST+ / ST-L	1,524L
Ti	1,513L
Ti e-POWER	1,518L



Unexpected cargo capacity

Up to 1,524L of space means the QASHQAI is ready to carry everything you need. Two luggage boards* offer 16 boot configurations for maximum flexibility, whatever your cargo. Smart features like the Nissan handsfree power tailgate* and wide opening rear doors take the hassle out of packing and unpacking, so you can make the most of your precious days out.

*Available on Ti only.



Safety at its heart

Every QASHQAI is equipped with advanced safety technologies designed to watch the road, help to keep you safe and give you maximum peace of mind.



INTELLIGENT CRUISE CONTROL helps you to keep your distance. It measures the distance from the vehicle ahead, controlling acceleration and deceleration to help to maintain a suitable following distance within your set speed.



INTELLIGENT FORWARD COLLISION WARNING keeps an eye up to two vehicles in front of you. When the system detects a sudden deceleration ahead, it gives you an audible and visual warning to slow down.



INTELLIGENT REAR AUTOMATIC BRAKING helps you back up with confidence. If an object is detected behind your vehicle, the system can automatically engage the brakes to help avoid a collision.



EMERGENCY LANE KEEPING A full suite of technologies to help you avoid unintentional lane departure. Keeps you centered in the lane using either a steering wheel action* or braking in an emergency situation.

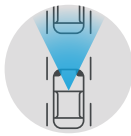

INTELLIGENT FORWARD BRAKE & JUNCTION ASSIST Monitors the surrounding area in front of the car for vehicles and pedestrians, helping to avoid or reduce damage caused by collisions with Junction Assist assisting further by monitoring what is around corners.





Shine a light on safety

The QASHQAI gives you added confidence when driving from dusk til dawn with Adaptive Driving Beam* Technology. It splits the high beam into 12 individual segments, automatically turning off segments which could dazzle oncoming drivers. Maximum visibility for you and for those around you.

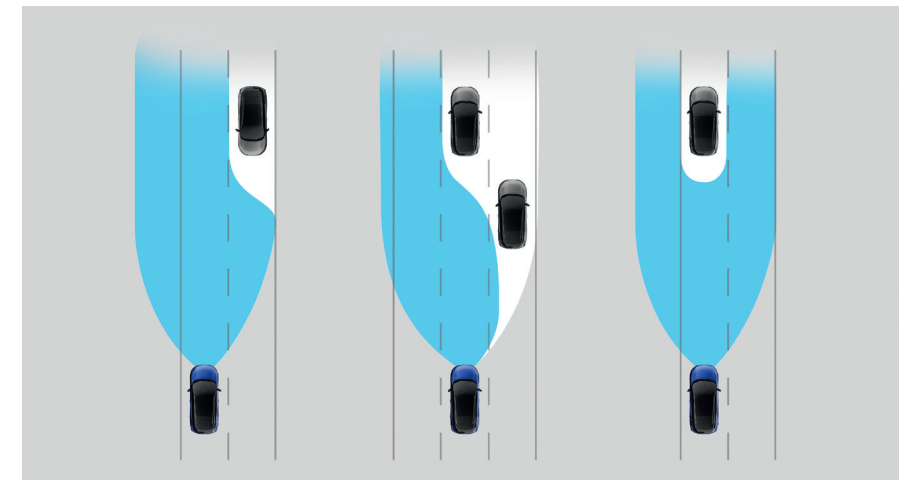

*Available on ST-L and TI grades only.



ProPILOT

The QASHQAI includes ProPILOT, ensuring comfortable, relaxed driving on major roads. ProPILOT is convenient and easy to use. Simply enable the system with the touch of a button on the steering wheel. It is a hands-on driver assist system that combines Nissan's Intelligent Cruise Control and Steering Assist technologies and includes a stop and hold function that can bring the vehicle to a full stop. If you're stopped, it will hold you in place and bring you back up to speed when traffic starts moving again. This technology supports a smoother drive, helping you keep safe in your lane, whilst assisting in maintaining an ideal and safe distance from the vehicle in front, whatever the gradient.

*Available on ST-L and Ti only.

ProPILOT is an Advanced Driver Assist technology but cannot prevent collisions. ProPILOT is intended for "Eyes on/Hands On" for highways only (road separated by Barriers). It is the driver's responsibility to stay alert, drive safely and remain in control of the vehicle at all times.

Tight spot? No problem

If you hate parking, you'll love the Nissan QASHQAI. The digital high resolution Around View Monitor* gives you a 360° view of your car, with selectable focus on the front, rear and kerbside view to help you park with confidence and control. Nissan QASHQAI Ti grade is also equipped with Intelligent Park Assist[^], offering automatic parking space detection and fully automatic control of the steering, with the driver taking care of the braking and accelerator when parking. Now parking really is child's play.



Rear camera lets you see what's right behind you.

Flick the switch to side camera view to see the kerb.

All-around view gives a virtual 360° birds' eye view as you manoeuvre.

Front camera gives combined front and overhead view for perfect parking.

*Available on ST+ grade and above. Around View Monitor is a driver's aid only. It cannot completely cover blind spots and may not detect moving objects. Always check surroundings before moving vehicle.

[^] Intelligent Park Assist is a driver's aid only and should not be used as a substitute for safe driving practices. Always monitor your surroundings when driving.



ST



Specification:

- 17" alloy wheels
- Multi-link rear suspension
- 8" touchscreen display with Apple CarPlay® and Android Auto™[^]
- DAB+ digital radio
- 7" TFT Advanced Drive-Assist® Display instrument cluster
- Cloth seat trim
- Black leather-accented* dashboard, door trim and front armrest
- Intelligent Key® with push button start
- Drive Mode Selector (Eco/Normal/Sport)
- Electronic park brake with auto hold function
- Paddle shifters
- Auto-fold heated door mirrors
- Automatic LED headlights with High Beam Assist
- LED Daytime Running Lights
- Rear view camera with predictive path
- Rear parking sensors
- Intelligent Driver Alert
- Intelligent Rear Automatic Braking (IRAB) with pedestrian detection
- Intelligent Blind Spot Intervention (IBSI)
- Blind Spot Warning (BSW)
- Rear Cross Traffic Alert (RCTA)
- Traffic Sign Recognition (TSR)
- Intelligent Emergency Braking (IEB) with pedestrian, cyclist detection and junction assist
- Intelligent Forward Collision Warning (IFCW)
- Intelligent Lane Intervention (ILI)
- Lane Departure Warning (LDW)
- Intelligent Cruise Control
- Rear air vents
- Rear spoiler
- Two rear ISOFIX childseat anchorage points with top tether
- Rear seat alert

*Leather accented features and upholstery may contain synthetic material.

[^]CarPlay is a registered trademark of Apple Inc. Android Auto is a trademark of Google LMC. Compatible device and USB connection required.

ST+



ST+ includes ST features plus/or:

- 18" alloy wheels
- 12.3" touchscreen display with wireless Apple CarPlay®[~]
- Satellite navigation
- Intelligent Around View Monitor with Moving Object Detection
- Automatic rain-sensing front wipers
- LED front fog lights
- Optional two-tone roof (available at extra cost)

[~]CarPlay is a registered trademark of Apple Inc. Compatible device required.

ST-L



ST-L includes ST+ features plus/or:

- 19" alloy wheels
- Automatic LED headlights with Adaptive Driving Beam
- Wireless phone charger*
- Dual-zone climate control†
- Heated leather-accented* steering wheel
- Heated front seats
- Part cloth/part-leather accented* seat trim
- 8-way power adjustable driver seat
- Manual lumbar support for passenger seat
- Rear seat armrest with two cup-holders
- Privacy glass (second row & rear windows)
- LED signature rear lights
- Auto-dimming rear view mirror
- Front parking sensors
- ProPILOT[^] (Lane Keep Assist)
- Roof rails

†Leather accented features and upholstery may contain synthetic material.

[^]ProPILOT is an Advanced Driver Assist technology but cannot prevent collisions. ProPILOT is intended for "Eyes on/Hands On" for highways only (road separated by Barriers). It is the driver's responsibility to stay alert, drive safely and remain in control of the vehicle at all times.

*Compatible device required.

Ti



Ti includes ST-L features plus/or:

- Optional e-POWER powertrain
- Advanced 10.8" Head-Up Display
- 12.3" TFT Advanced Drive-Assist[®] Display instrument cluster
- 10-speaker Bose[®] audio system with Bose[®] Acoustimass[™] Bass Box
- Intelligent Park Assist with Parking System Monitor
- Panoramic glass roof with electric sunshade
- Premium 3D quilted leather-accented* seat trim
- 8-way power adjustable driver and passenger seat
- Massage driver and passenger seats
- Memory function for driver seat
- Black headlining
- Premium graphite rear bumper finisher
- Handsfree power tailgate
- Divide-N-Hide[®] configurable cargo system
- Advanced Intelligent Key with driver memory storage
- Ambient door lighting

e-POWER only

- Vehicle approach sound for Pedestrians (in reverse)
- Premium Front Grille
- Regenerative Braking
- e-Pedal Step

†Leather accented features and upholstery may contain synthetic material.

Your weekend
adventure awaits



Ti model shown with roof cross bars not available on all grades.

Nissan Genuine Accessories

Personalise your Nissan QASHQAI with our range of Nissan Genuine Accessories, designed to add style, functionality and protection

Style

Featuring a front, side and rear chrome finisher, the STYLE pack adds a stylish finish to the exterior of your new Nissan QASHQAI.

Protect

Featuring a luggage entry scuff plate, carpet floor mats, door entry kick plates, front & rear mud guards, and a first aid kit, keep your Nissan QASHQAI in new condition for longer with the PROTECT Pack.

Adventure

The QASHQAI ADVENTURE Pack is purpose built for epic weekend adventures and includes a towbar & wiring harness, roof cross bars* and a safety pack.



A



D



G



B



C



E



F



H



I

Why Choose Genuine?



Safety

Your safety is our priority. That's why we put Nissan Genuine Accessories through thousands of hours of testing.



Reliability

Nissan Genuine Accessories are made for reliability and are covered by the Nissan New Vehicle Warranty when fitted at the time of vehicle purchase.*



Perfect Fit

Crafted to fit your Nissan perfectly, Nissan Genuine Accessories ensure optimum performance.



Future Proof

Nissan Genuine Accessories keep your vehicle complete and help maintain its resale value.

Style Accessory Pack

- A Front chrome finisher
- B Side chrome finisher
- C Rear chrome finisher

Protect Accessory Pack

- D Luggage entry scuff plate
- E Velour Carpet Floor Mats
- F Front & Rear Mud Guards

Adventure Accessory Pack

- G Roof Cross Bars
- H Towbar
- I Safety Pack

Accessory Pack contents may differ depending on model grade. Additional costs may apply. Recommended fit price may differ between Dealers. Please refer to your Nissan Dealer for model applicability & recommended fit price.

* Front door entry kick plates and first aid kit not pictured.

^ Roof cross bars shown on model grade with roof rails as standard. Not applicable to all models.

- Nissan Genuine Accessories are built to Nissan's exacting quality standards and are backed by the confidence of Nissan's five (5) year unlimited kilometre New Vehicle Warranty when fitted to a vehicle in a Nissan authorised workshop at the time of vehicle purchase. If purchased after delivery of the vehicle and fitted by an authorised Nissan Dealer, Nissan Genuine Accessories will be covered by Nissan's one (1) year or 20,000km warranty or balance of the New Vehicle Warranty (whichever is greater). Nissan Genuine Accessories purchased over the counter are covered from sale date by Nissan's one (1) year or 20,000km warranty (whichever occurs first). Note: Our goods come with guarantees that cannot be excluded under the Australian Consumer Law. The customer is entitled to a replacement or refund for a major failure and compensation for any other reasonably foreseeable loss or damage. The customer is also entitled to have the goods repaired or replaced if goods fail to be of acceptable quality and the failure does not amount to a major failure.

WHEELS



ST
17" Alloy



ST+
18" Alloy



ST-L and Ti
19" Alloy

TRIMS



ST and ST+
Cloth



ST-L Blue & Black –
Cloth and leather-
accented* Monoform
Seats



Ti Blue & Black –
Premium quilted
leather-accented*
Monoform Seats

*Leather-accented features and upholstery may contain synthetic material.

DIMENSIONS

- A: Overall length: 4,425M
- B: Wheelbase: 2,665M
- C: Overall width: 1,835M
- D: Overall height: 1,625M



B

A



C

D

Ti model shown with optional two tone roof.

COLOUR PALETTE

8 BODY COLOURS



Ceramic Grey - P[^]



Ivory Pearl -P[^]



Magnetic Blue - P



Pearl Black - M[^]



Gun Metallic - M[^]



Platinum - M[^]



Burgundy - M[^]



Fuji Sunset Red - M[^]

P: Pearl - M: Metallic - S: Solid

5 TWO-TONE COLOURS[^]



Two-tone Ceramic Grey
with Pearl Black Roof



Two-tone Ivory Pearl with
Pearl Black Roof



Two-tone Magnetic Blue
with Pearl Black Roof



Two-tone Pearl Black with
Gun Metallic Roof



Two-tone Fuji Sunset Red
with Pearl Black Roof

A complete ownership experience to help you get the most out of your Nissan. It includes the following:

NISSAN CAPPED PRICE SERVICE

All Nissan vehicles first registered from 1 January 2018 are eligible for Nissan Capped Price Service. As part of this servicing program, we've capped the maximum price you'll pay for the first six services according to your vehicle's service schedule[#].

5 YEAR/UNLIMITED WARRANTY

Receive assurance with a 5 year/unlimited warranty[†].

5 YEARS ROADSIDE ASSISTANCE

No matter where you're planning to journey, you'll have the peace of mind of knowing that if you lock your keys in the car, have a flat tyre or battery, or run out of fuel, we'll help get you back on the road at no charge[‡].

OPTIONAL PRE-PAID MAINTENANCE PLANS

Our optional Pre-paid Maintenance Plan takes the hassle out of budgeting for scheduled service costs over time, instead offering you the convenience of a one-off payment when you purchase your new Nissan vehicle.

NISSAN GENUINE ACCESSORIES

Your Nissan Dealer can show you a variety of Nissan Genuine Accessories to protect, enhance and personalise your Nissan QASHQAI.

FINANCIAL SERVICES

Choose from a range of finance options at very competitive rates and terms, as well as various insurance solutions to protect you and your vehicle.

[#] Ask your Nissan Dealer to explain exactly what items are covered in each Scheduled Service. Applies for up to 6 years/90,000km (whichever occurs first). Some exclusions apply.

Ask your Nissan Dealer or visit nissan.com.au/service to find out more and for full terms and conditions.

[†] Conditions apply. See nissan.com.au/warranty for more details. NOTE: Our goods come with guarantees that cannot be excluded under the Australian Consumer Law. You are entitled to a replacement or refund for a major failure and compensation for any other reasonably foreseeable loss or damage. You are also entitled to have the goods repaired or replaced if goods fail to be of acceptable quality and the failure does not amount to a major failure.

[‡] Terms and conditions apply, please visit nissan.com.au/roadsideassistance

[^] Premium paint available at extra cost. Two-tone paint not available on ST variants.

Specifications

	ST	ST+	ST-L	Ti	Ti e-POWER
Drivetrain					
HR13 - 1.3 litre Turbocharged in-line 4-cylinder, 16-valve					
Power - 110kW @ 5,500 rpm	•	•	•	•	
Torque - 250Nm @ 1,600-3,750 rpm					
Idle Stop/Start System	•	•	•	•	
Xtronic CVT (Continuously Variable Transmission) Automatic	•	•	•	•	
Direct Injection Gasoline - Turbocharged (DIG-T)	•	•	•	•	
Front engine/Front-wheel Drive	•	•	•	•	•
Drive mode selector (Sport, Normal, Eco)	•	•	•	•	•
KR15 - 1.5 litre Turbocharged in-line 3-cylinder, 12-valve, Variable Compression Ratio					•
Electric Motor Outputs					•
Power - 140kW @ 4,500-7,500 rpm					•
Torque - 330Nm @ 0-3,000 rpm					•
Reduction Drive (Automatic)					•

Brakes					
Anti-lock Braking System	•	•	•	•	•
Vehicle Dynamic Control	•	•	•	•	•
Electronic Brakeforce Distribution	•	•	•	•	•
Electronic Stability Programme	•	•	•	•	•
Traction Control System	•	•	•	•	•
Brake Assist	•	•	•	•	•
Hill Start Assist	•	•	•	•	•
Front and rear ventilated disc brakes	•	•	•	•	•
Electric Park Brake with Auto Hold Function	•	•	•	•	•
Active Brake Limited Slip	•	•	•	•	•

Suspension / Steering					
MacPherson strut front suspension	•	•	•	•	•
Multi-link rear suspension	•	•	•	•	•
Front and rear stabiliser bars	•	•	•	•	•
Electronic Power Steering	•	•	•	•	•

Safety & Security					
Height adjustable front and rear headrests	•	•	•	•	•
Front seat belts with load limiter and pretensioner	•	•	•	•	•
Height adjustable front seat belts	•	•	•	•	•
3-point rear seat belts with load limiter and pretensioner	•	•	•	•	•
Seatbelt reminder (front and rear)	•	•	•	•	•
Remote central door locking with deadlocking (drivers side)	•	•	•	•	•
Rear door childlocks	•	•	•	•	•
Rear seat/door alert	•	•	•	•	•
Engine immobiliser	•	•	•	•	•
Rear View Camera with predictive path	•	•	•	•	•
Rear Parking Sensors	•	•	•	•	•
Intelligent Driver Alert	•	•	•	•	•

Specifications

	ST	ST+	ST-L	Ti	Ti e-POWER
Intelligent Rear Automatic Braking	•	•	•	•	•
Intelligent Blind Spot Intervention	•	•	•	•	•
Blind Spot Warning	•	•	•	•	•
Rear Cross Traffic Alert	•	•	•	•	•
Traffic Sign Recognition	•	•	•	•	•
Intelligent Emergency Braking with pedestrian, cyclist detection and junction assist	•	•	•	•	•
Intelligent Forward Collision Warning	•	•	•	•	•
Intelligent Lane Intervention	•	•	•	•	•
Lane Departure Warning	•	•	•	•	•
Tyre Pressure Monitoring System	•	•	•	•	•
Active Speed Limiter	•	•	•	•	•
Cruise Control	•	•	•	•	•
Intelligent Cruise Control	•	•	•	•	•
Intelligent Around View Monitor with Moving Object Detection		•	•	•	•
Front Parking Sensors			•	•	•
ProPILOT [®] (Lane Keep Assist)			•	•	•
Alarm System			•	•	•
Intelligent Park Assist with Parking System Monitor				•	•
Vehicle approach sound for Pedestrians (In Reverse)					•

Airbags					
Driver and front passenger front impact SRS airbags (x2)	•	•	•	•	•
Driver and front passenger side impact SRS airbags (x2)	•	•	•	•	•
Front to rear SRS curtain airbags (x2)	•	•	•	•	•
Front far-side airbag (centre)	•	•	•	•	•

Comfort & Convenience					
One Touch front and rear electric windows with remote opening/closing	•	•	•	•	•
7" High Definition full colour TFT screen combimeter	•	•	•		
12.3" TFT digital combimeter				•	•
Advanced 10.8" Windscreen Head-Up Display				•	•
Push button start	•	•	•	•	•
Intelligent Key	•	•	•		
Advanced Intelligent Key with Driver Memory Storage (driver seat, mirrors, audio) and Remote tailgate opening				•	•
Rear air vents	•	•	•	•	•
Manual air conditioning	•	•			
Automatic dual zone climate control			•	•	•
Steering wheel mounted gearshift paddles	•	•	•	•	
Front cupholders (x2)	•	•	•	•	•
Front and rear bottle holders (x4)	•	•	•	•	•
Sunglass holder	•	•	•		
Front centre console and armrest	•	•	•	•	•
Centre console with tray insert			•	•	•
Rear seat armrest with 2 cupholders			•	•	•
Trip computer	•	•	•	•	•
Three Blink Turn Signal	•	•	•	•	•
Luggage space lighting	•	•	•	•	•
Follow Me Home Headlights	•	•	•	•	•

Specifications

	ST	ST+	ST-L	Ti	Ti e-POWER
Splash-Free Wipers	•	•	•	•	•
Auto Rear Wiper when reversing	•	•	•	•	•
Speed-sensitive variable intermittent windshield wipers	•	•	•	•	•
Rain-sensing front wipers		•	•	•	•
Electrically adjustable and heated door mirrors with LED turn indicator	•	•	•	•	•
Auto-folding mirrors	•	•	•	•	•
Door mirrors with memory function with tilt when reversing				•	•
Rear luggage bag hooks (x2)	•	•	•	•	•
Rear Luggage hooks (x4)			•	•	•
Auto-dimming rear view mirror			•	•	•
Hands-Free automatic opening power tailgate				•	•
Luggage board system				•	•

Audio & Connectivity

8" Touchscreen Infotainment System	•				
12.3" Touchscreen Infotainment System with HD Resolution		•	•	•	•
Satellite navigation		•	•	•	•
Apple CarPlay® and Android Auto®	•	•	•	•	•
Wireless Apple CarPlay®		•	•	•	•
Wireless phone charger†			•	•	•
AM/FM audio system with Digital Radio (DAB+)	•	•	•	•	•
Bluetooth® with audio streaming and handsfree phone systemº	•	•	•	•	•
Voice Recognition	•	•	•	•	•
Front centre console USB connections (Type-A and Type-C)	•	•	•	•	•
Rear USB charging only ports (Type-A and Type-C)	•	•	•	•	•
12V power sockets in dashboard and luggage space	•	•	•	•	•
6 speakers	•	•	•		
10 Bose® Speakers: 2 Tweeters, 6 high and medium frequency door/front pillar speakers, 2 in the Subwoofer				•	•
Bose® Acoustimass™ Bass Box				•	•
Digital Amplifier				•	•

Exterior

Chrome side window finisher	•	•	•	•	•
Body coloured door handles	•	•	•	•	•
Body Side mouldings	•	•	•	•	•
Body coloured mirror caps	•	•	•	•	•
Pearl Black coloured mirror caps		◦	◦	◦	◦
Rear roof spoiler	•	•	•	•	•
Shark fin antenna	•	•	•	•	•
Rear privacy glass			•	•	•
Roof rails			•	•	•
Panoramic glass roof with electric sunshade				•	•
Premium graphite rear bumper finisher				•	•
Premium Front Grille					•
e-POWER badges (rear and front doors)					•

Specifications

	ST	ST+	ST-L	Ti	Ti e-POWER
Lighting					
LED Daytime Running Lights	•	•	•	•	•
LED rear taillights	•	•	•	•	•
LED Signature Rear Lights			•	•	•
Automatic LED headlights with High Beam Assist (HBA)	•	•			
Automatic LED headlights with Adaptive Driving Beam			•	•	•
Headlights Auto Levelling System			•	•	•
LED Front Fog lights		•	•	•	•
Wheels / Tyres					
17" x 70" alloy wheels with 215/65 R17 tyres	•				
18" x 75" alloy wheels with 235/55 R18 tyres		•			
19" x 75" alloy wheels with 235/50 R19 tyres			•	•	•
Temporary Wheel - 155/90 R17 tyre	•	•	•	•	
Tyre Repair Kit					•

Interior

Urethane wrapped steering wheel	•	•			
Leather-accented* steering wheel			•	•	•
Leather-accented* shift knob	•	•	•	•	
Tilt and telescopic steering wheel adjustment	•	•	•	•	•
Multifunctional D-shape Steering wheel	•	•	•	•	•
Electric speed-sensitive power steering	•	•	•	•	•
Heated steering wheel			•	•	•
60/40 split folding rear seats	•	•	•	•	•
Driver and front passenger seat pockets	•	•	•	•	•
Interior Chrome door handles	•	•	•	•	•
Driver and passenger sun visor with illuminated vanity mirrors	•	•	•	•	•
Welcome Light and Console Tray Ambient Lighting	•	•	•		
Front Door Ambient Lighting				•	•
e-Shifter with Regenerative Braking mode					•
e-Pedal Step mode button					•
EV mode button					•

Seating

6-way manual adjustable driver seat	•	•			
4-way manual adjustable front passenger seat	•	•			
Electrically adjustable lumbar support on driver seat	•	•	•		
8-way Electrically adjustable driver seat			•		
6-way manual adjustable front passenger seat with manual lumbar support			•		
8-way Electrically adjustable driver seat with memory function				•	•
8-way Electrically adjustable passenger seat				•	•
Electrically adjustable 4-way lumbar support on driver & passenger seat				•	•
Massage front seats (3 functions)				•	•
Heated front seats			•	•	•
Child restraint anchorage (2nd row RH/LH ISOFIX + tether and centre tether)	•	•	•	•	•

Trim

Black leather-accented* dashboard, door trim and front armrest	•	•			
Charcoal - Cloth Monoform Seats	•	•			

Specifications

	ST	ST+	ST-L	Ti	Ti e-POWER
Blue & Black - Cloth and Leather-accented [†] Monoform Seats			●		
Blue & Black leather-accented [†] dashboard, knee pad, door trim and front armrest			●	●	●
Black - Premium quilted leather-accented [†] Monoform Seats				●	●
Black headlining				●	●

Dimensions (mm)					
Exterior					
Overall length	4,425				
Overall width (without mirrors)	1,835				
Overall width (with mirrors)	2,084				
Overall height	1,625				
Wheelbase	2,665				
Track width (unladen) - front/rear	1,590 / 1,596	1,580 / 1,586			
Ground clearance (minimum)	180			175	
Front Approach/Departure Angle (degrees)	173				
Rear Approach/Departure Angle (degrees)	25.9				
Turning circle (m) - Kerb to Kerb	11.1				
Door opening angle - Front/Rear (degrees)	70 / 85				
Interior (1st / 2nd row) (mm)					
Head room (front/rear)	997 / 983			994 / 950	
Leg room (front/rear)	1,072 / 860				
Shoulder room (front/rear)	1,436 / 1,415				
Hip room (front/rear)	1,362 / 1,335				

Capacities					
Seating capacity	5				
Cargo capacity with 2nd row upright (litres)	429			418	452
Cargo capacity with 2nd row folded (litres)	1,524			1,513	1,518
Fuel tank (litres)	55				
Maximum towing capacity [€] - braked (kg)	1,500				750
Maximum towing capacity [€] - unbraked (kg)	750				

Weights (kg)					
Kerb weight [†]	1,451	1,472	1,482	1,524	1,728
Gross vehicle mass ^{††}	1,985				2,180

Fuel Economy					
Fuel consumption ^{**} (L/100km) - Combined	6.1				5.2
CO2 emission ^{**} (g/km)	138				117
Fuel requirement (minimum/recommended, RON)	91/95				

Warranty					
Nissan 5 Year Warranty ^{**}	●	●	●	●	●
5 year 24-Hour Roadside Assistance Program [†]	●	●	●	●	●
Capped Price Service with 12 month/15,000km intervals (whichever comes first) ^M	●	●	●	●	
Capped Price Service with 12 month/10,000km intervals (whichever comes first) ^M					●

Specifications

	ST	ST+	ST-L	Ti	Ti e-POWER
Colours					
Gun Metallic (KAD) [*]	●	●	●	●	●
Ceramic Grey (KBY) [*]	●	●	●	●	●
Platinum (KYO) [*]	●	●	●	●	●
Burgundy (NBQ) [*]	●	●	●	●	●
Fuji Sunset Red (NBV) [*]	●	●	●	●	●
Ivory Pearl (QAB) [*]	●	●	●	●	●
Magnetic Blue (RCF)	●	●	●	●	●
Pearl Black (Z11) [*]	●	●	●	●	●
Two-tone Ivory Pearl with Pearl Black Roof (XDF) ^{†µ}		○	○	○	○
Two-tone Pearl Black with Gun Metallic Roof (XDK) ^{†µ}		○	○	○	○
Two-tone Fuji Sunset Red with Pearl Black Roof (XEY) ^{†µ}		○	○	○	○
Two-tone Ceramic Grey with Pearl Black Roof (XFU) ^{†µ}		○	○	○	○
Two-tone Magnetic Blue with Pearl Black Roof (XFV) [†]		○	○	○	○

Not available

Standard

With two-tone roof option

^{**} GVM = Gross Vehicle Mass. GVM is the maximum laden mass of a motor vehicle.

[~] Kerb weight = unladen mass of vehicle with full fuel.

[‡] Indicates a premium paint, which is available at extra cost.

^µ Indicates Two-tone paint, which is available at extra cost

[∞] Figures tested in accordance with ADR81/02 (combined test), for the purposes of comparison amongst vehicles only. Actual fuel consumption and CO2 emissions depends on factors such as traffic conditions, vehicle condition, how you drive and any accessories fitted

[†] Leather accented features and upholstery may contain synthetic material.

^Δ ProPILOT cannot prevent collisions. It is the driver's responsibility to be in control of the vehicle at all times. Always monitor traffic conditions and keep both hands

on the steering wheel. System operates only when lane markings are detected. Does not function in all weather, traffic and road conditions. System has limited control capability and the driver may need to steer, brake or accelerate at any time to maintain safety. See Owner's Manual for safety information.

[○] The Bluetooth® word marks are registered trade marks owned by Bluetooth SIG, Inc. Availability of specific features is dependent upon the phone's Bluetooth® support. Refer to your phone owner's manual for details.

[^] CarPlay is a registered trademark of Apple Inc. Android Auto is a trademark of Google LLC. Compatible device required. Wired connections require a USB connection.

^Ω Bose and Acoustimass® are registered trade marks of Bose Corporation

[€] Towing capacity is subject to towbar/towball capacity and is based on the fitment of a Genuine Nissan towbar. Towing capacity figure described is a maximum figure. Actual towing capacity depends on the laden mass of the vehicle, driving conditions, fitment of any accessories or towing equipment limitations including the maximum towball download.

[#] Compatible device required.

^{††} Conditions apply. See nissan.com.au/warranty for more details.

^{*} Terms and conditions apply, please visit nissan.com.au/roadsideassistance.

^M Ask your Nissan Dealer to explain exactly what items are covered in each Scheduled Service. Applies for up to 6 years/90,000kms (whichever occurs first). Some exclusions apply. Ask your Nissan Dealer or visit nissan.com.au/service to find out more and for full terms and conditions.



Nissan Intelligent Mobility guides everything we do. At Nissan, we use new technologies to transform cars from mere transportation. Together the journey is more confident, connected, and exciting. Whether it is cars that share the task of driving or highways that charge your EV as you go along, it's all in the very near future. And it's a future already taking shape in the Nissan you drive today.

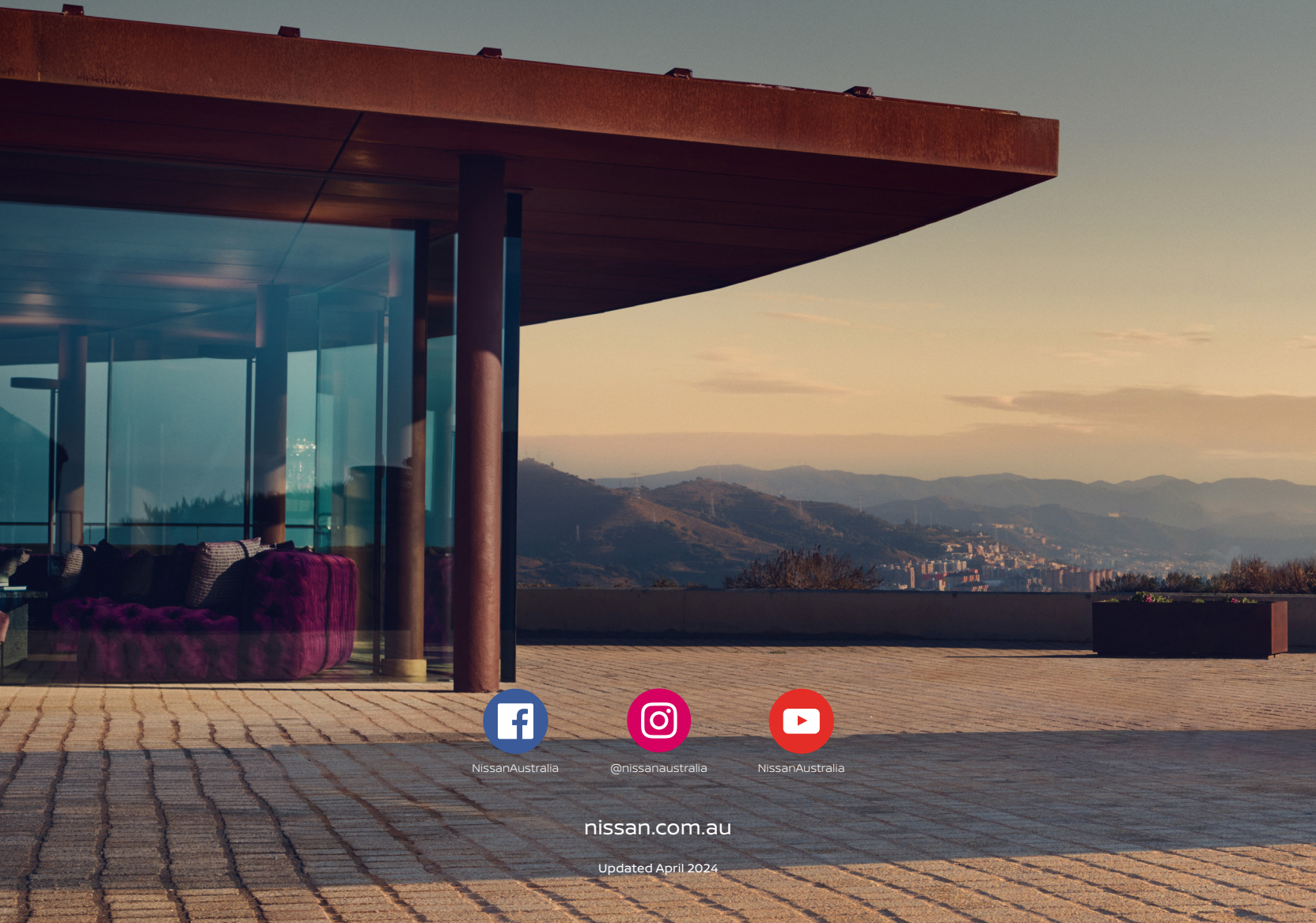

NissanAustralia



@nissanaustralia



NissanAustralia

nissan.com.au

Updated April 2024